

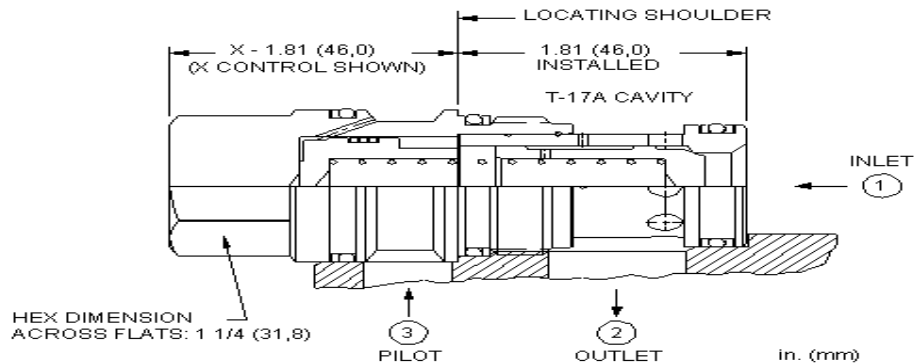

GPCC17

Check Valve

Pilot to Close
80 gpm (320 L/min)
T-17A Cavity

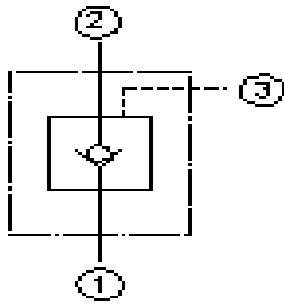

Operation Pilot to close check allows free flow from the valve port to the cylinder port and prevents reverse flow with no pilot pressure. With adequate pilot pressure applied to the pilot port, the pilot piston unseats the check poppet allowing reverse flow. Minimum pilot pressure required to open this valve is found by dividing the cylinder pressure by the valve's pilot ratio. (ex. 1500 psi @ cylinder / (3:1) = 500 psi minimum pilot pressure required.)

Type Poppet type check valve with an internal pilot piston.

Material Precision ground & honed, hardened steel parts. Buna-N seals standard. Zinc plated.

Maximum Pressure 5,000 psi (350 bar)

Pilot ratio 1.8:1

Flow 80 gpm nominal (320 L/min)

Leakage 5 drops per minute (.35cc/min)

Fluid General hydraulic fluid

Cavity T-17A

Install torque 150-160 lb-ft (200-215Nm)

Options

GPCC17

Basic cartridge

- 1.8

Pilot Ratio
1.8 - 1.8:1

30

Cracking Pressure
4 - 4 psi
30 - 30 psi
75 - 75 psi

- N

Seals
N - Buna-N
V - Viton

