

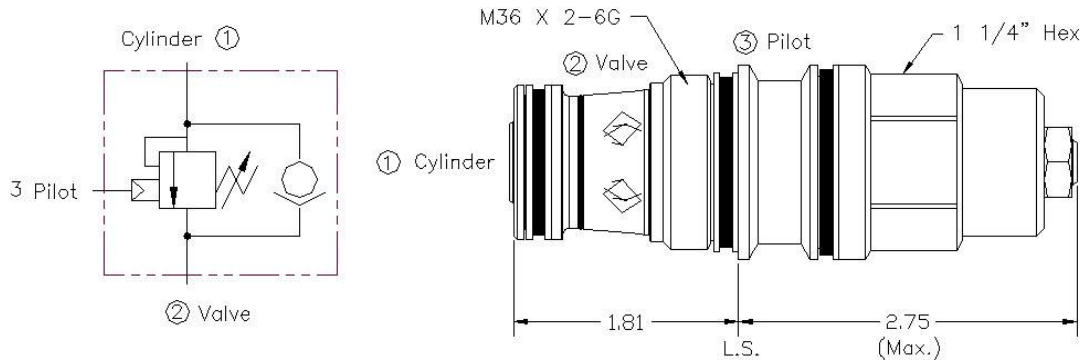

Gold Series

GCB17-10 Counterbalance Valve

10:1 Pilot Ratio
60 GPM (240 L/min)
T-17A Cavity



Operation	Counterbalance valve prevents load runaway. Allows free flow from 2 to 1 & controlled flow from 1 to 2 by direct acting relief with a pilot operator to override or assist. Set relief at 30% above the maximum normal operating pressure. No pilot seals. Leakage port 2 to 3, 2 cu in/min at 1000psi.	
Pilot Ratio	10:1	
Material	All steel construction. Precision ground & hardened parts. Buna-n seals are standard, viton available as an option.	
Maximum Pressure	4,000 psi	(280 bar)
Nominal Flow	60 gpm	(240 L/min)
Leakage	5 Drops/ min @ 85% of set pressure	
Reset	>85% of setting	
Fluid	General hydraulic fluid	
Cavity	T-17A	
Install Torque	150 - 160 LB-FT (200 - 215 Nm)	

Options

GCB17	-	10		25		A	-	N		XXXX
Basic cartridge		Pilot Ratio 10 - 10:1		Adjustment Range 25 - 1000 - 2500 psi (std. set 2000psi) 50 - 2000-4000 psi (std. set 3000 psi)		Cracking Pressure A- 4psi Omit- 25psi		Seals N- Buna-n V- Viton		Factory Setting xx-In psi (ie 2000=2000psi)

Free Flow and Piloted Open Pressure Drop

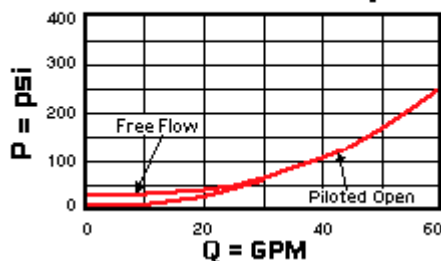

Typical Relief Characteristics

