

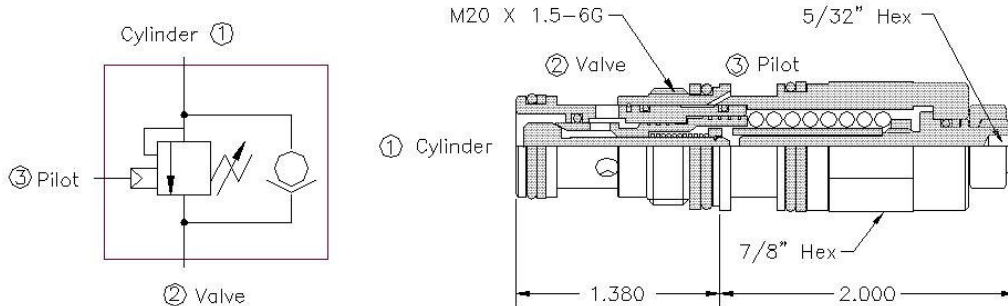

Gold Series GCB11-4 Counterbalance Valve

4.5:1 Pilot Ratio
15 GPM (60 L/min)
T-11A Cavity



Operation	Counterbalance valve prevents load runaway. Allows free flow from 2 to 1 & controlled flow from 1 to 2 by direct acting relief with a pilot operator to override or assist. Set relief at 30% above the maximum normal operating pressure. No pilot seals. Leakage port 2 to 3, 2 cu in/min at 1000psi.	
Pilot Ratio	4.5:1	
Material	All steel construction. Precision ground & hardened parts. Buna-n seals are standard, viton available as an option.	
Maximum Pressure	4,000 psi	(280 bar)
Nominal Flow	15 gpm	(60 L/min)
Leakage	5 Drops/ min @ 85% of set pressure	(0.4cc/min)
Reseat	>85% of setting	
Fluid	General hydraulic fluid	
Cavity	T-11A	
Install Torque	30-35 LB-FT	(45 – 50 Nm)

Options

GCB11	- 4	25	A	- N	XXXX
Basic cartridge	Pilot Ratio 4 - 4.5:1	Adjustment Range 25 - 1000 - 2500 psi (std. set 2000psi) 50 - 2000-5000 psi (std. set 3000 psi)	Cracking Pressure A- 4psi Omit- 25psi	Seals N- Buna-n V- Viton	Factory Setting xx-In psi 2000=2000psi

